

LED SMART RETROFIT DOWNLIGHTS

STEPPED BAFFLE



STARFISH™
Controlled with App

E26 Adapter Included

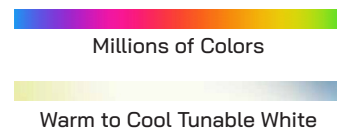

**4" & 6" MODELS IN ROUND
& SQUARE**

**STEPPED BAFFLE REDUCES
GLARE**

**STARFISH™ SMART ENABLED
PRODUCT**

**RGB, COLOR-CHANGING &
TUNABLE WHITE**

PRE-SET & CUSTOM EFFECTS

SUGGESTED APPLICATIONS

Residential, Multifamily
Commercial, Hospitality,
Offices

SATCO|NUVO's LED Retrofit Downlights with STARFISH™ technology are the ultimate choice for smart lighting and ambiance control. Download the STARFISH™ app to customize any tunable white color temperatures from 2000K warm white light to 5000K natural light, or choose from millions of colors on the RGB spectrum, all from your mobile device. Available in round and square with stepped baffle, these trims offer added dimension while reducing glare.

These downlights are also compatible with Siri, Alexa, Google Home, and SmartThings so they can be easily incorporated into your smart home.



WIFI
2.4GHz
No Hub Required



GENERAL SPECIFICATIONS

Input Voltage, Frequency: 120V, 60Hz
Power Factor, THD%: >0.9, <30%
Tunable White: 2000K-5000K CCT
RGB: Millions of Colors
Dimmable: Only with Starfish App
CRI: 90
Efficacy: up to 65 LPW
Beam Angle: 110°

Construction: Aluminum
Finish: White
Lens: Polycarbonate
Ambient Operating Temperature: -20°C (-4°F) to +40°C (+104°F)
Location Rating: Wet
IC Rating: Yes



ITEM SPECIFICATIONS / ORDER INFO

Item	Size	Shape	Lumens	Wattage	Incandescent Replacement Wattage	Input Current	Master Carton
S11568	4"	Round	650	10.5W	50W	0.09A	24
S11569	4"	Square	650	10.5W	50W	0.09A	24
S11570	6"	Round	850	13W	65W	0.11A	12
S11571	6"	Square	850	13W	65W	0.11A	12

DIMENSIONS/WEIGHTS

Item	Diameter/Width (A)	Length (B)	Height (C)	Weight
S11568	5.00"	•	2.71"	0.40 Lbs.
S11569	5.00"	5.00"	2.71"	0.57 Lbs.
S11570	7.32"	•	3.03"	0.57 Lbs.
S11571	6.77"	6.77"	3.38"	0.97 Lbs.

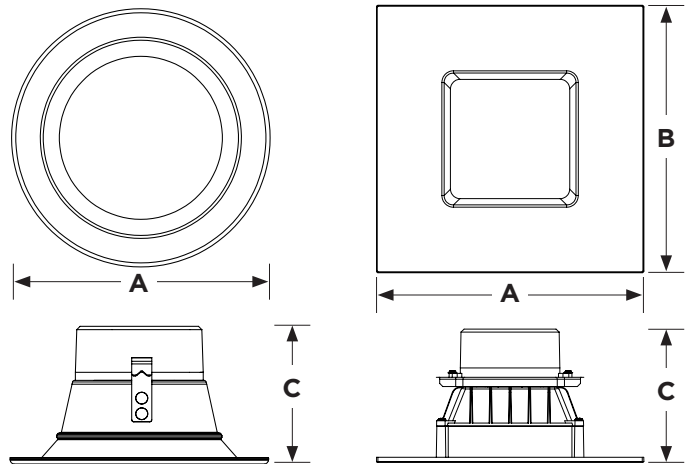

STARFISH™
 live life enl:ghtened



DOWNLOAD THE STARFISH APP



CONNECT
 Download the STARFISH™ app

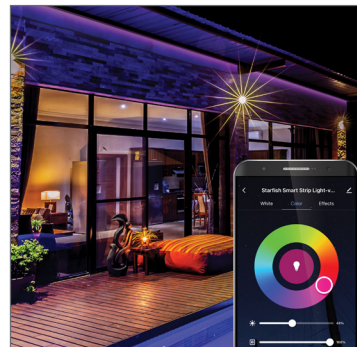

INSTALL
 Pair the smart downlights and configure your settings



ENJOY
 The convenience and customization of smart lighting

This device complies with Part 15 of the FCC Rules. Operation is subject to the following two conditions: (1) this device may not cause harmful interference, and (2) this device must accept any interference received, including interference that may cause undesired operation.

WARNING: Some products included in this specification sheet may be subject to the warning requirements of California's Proposition 65. Please refer to your product packaging for more information.

Replacement wattage shown depends on application and fixture. Specifications are subject to change without prior notice.

Amazon, Alexa and all related logos are trademarks of Amazon.com, Inc. and its affiliates. Siri is a registered trademark of Apple Inc. Google, Google Play and Google Home are trademarks of Google LLC.